

Rear Outswing of a Semitrailer with a Rear-mounted Device

John R. Billing

Meeting of Task Force on
Vehicle Weights and Dimensions Policy

Montreal, 20 November 2006

1

Aerodynamic Device

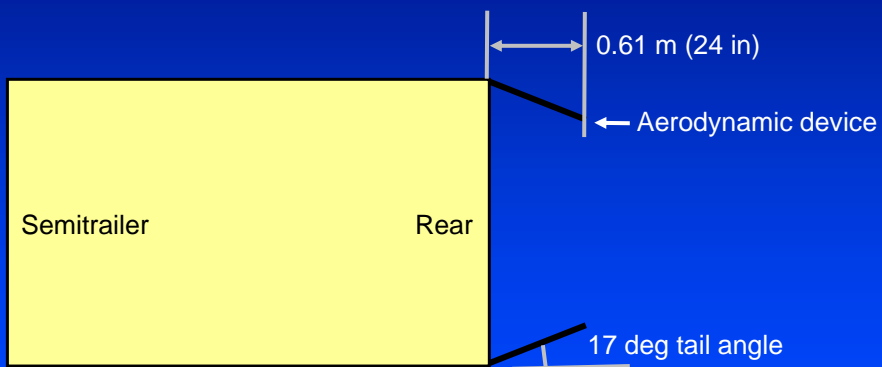

2

Issue

- Do these aerodynamic devices affect rear outswing for a 53 ft semitrailer with 35% effective rear overhang in a low-speed right-hand turn?

3

Rear Outswing

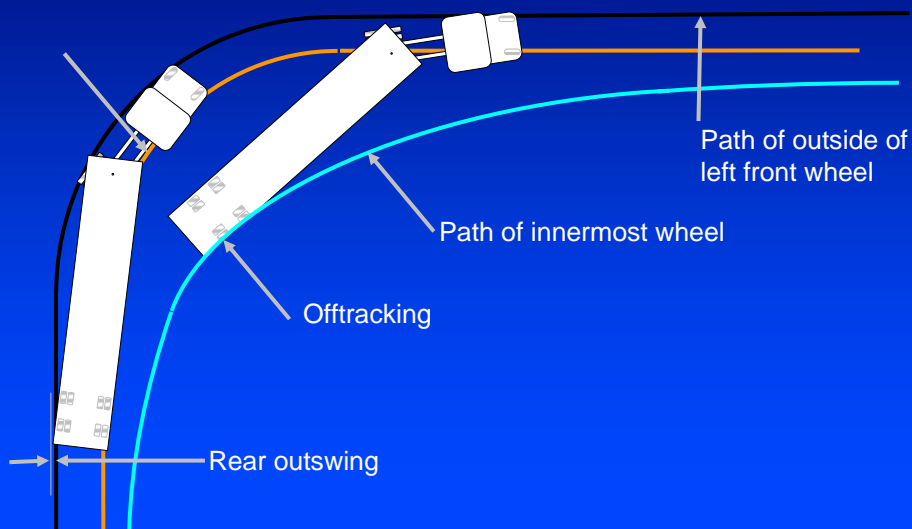

4

No Additional Outswing if Tail Angle > Yaw Angle

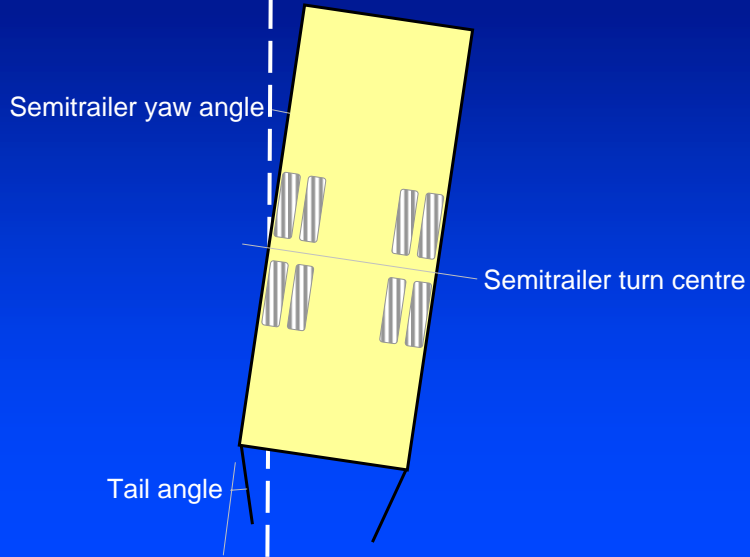

Vehicle Configuration

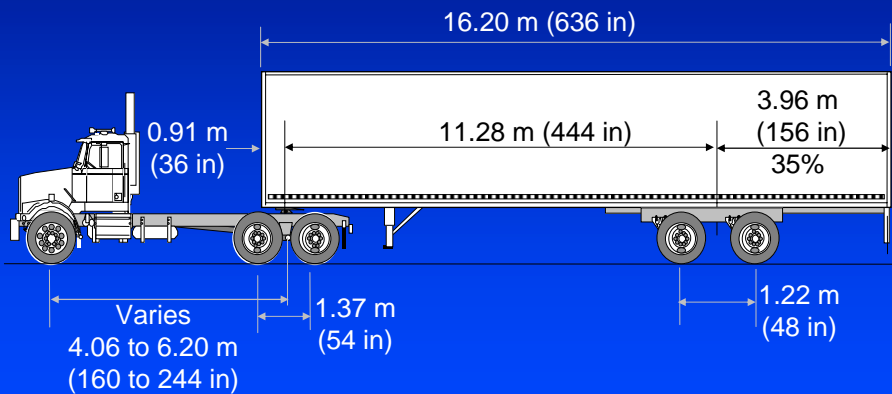

Rear Outswing

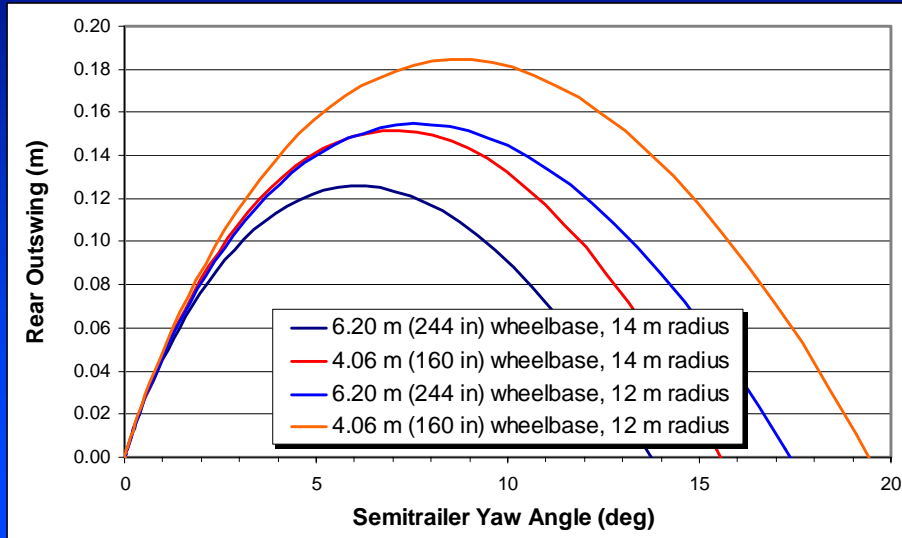

Conclusions

- A rear-mounted aerodynamic device will not increase rear outswing if it has a tail angle less than the yaw angle at which maximum rear outswing occurs
- Maximum rear outswing occurs at a yaw angle of 6 to 9 deg
- The aerodynamic device tail angle is 17 deg
- The aerodynamic device will not increase rear outswing

More General Conclusion

- The yaw angle for maximum rear outswing is 6 to 9 deg
- A conservative value would perhaps be 12 deg
- Any rear-mounted device, or overhanging cargo, will not affect rear outswing if the device or cargo is entirely included within a tail angle greater than 12 deg

9

Consequence

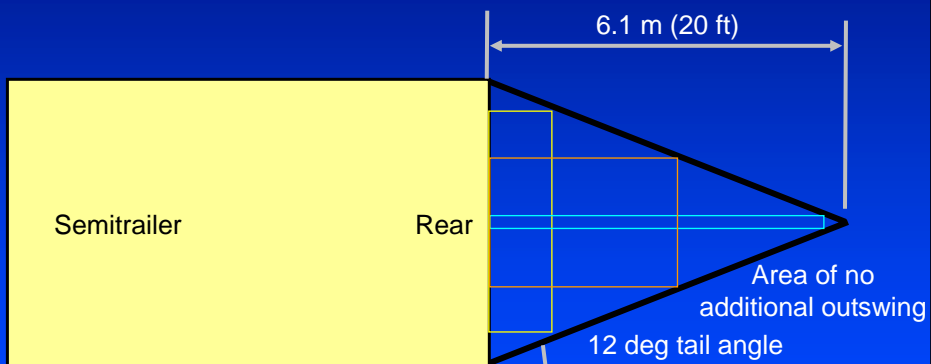

10