

Front Outswing of Extended Semitrailers

John R. Billing

Task Force on
Vehicle Weights and Dimensions Policy
3 December 2015

Semitrailer Length

- By performance standards
 - 2 m swing radius = 1.55 m kingpin setback
 - 12.5 m wheelbase
 - 35% rear overhang = $0.35 * 12.5 = 4.37$ m
 - $1.55 + 12.5 + 4.37 = 18.4$ m (60 ft 3 in)
- The provinces and industry had difficulty accommodating the length increase from 14 to 14.65 m (46 to 48 ft) in the mid 1980's

Semitrailer Length

- The M.o.U. initially proposed 16.2 m (53 ft)
- This proved unacceptable in Ontario
- The four western provinces proceeded at 53 ft
- The six eastern provinces remained at 48 ft
- By 1994, the flood of 53 ft trailers from the US had become unmanageable, so Ontario relented and these provinces adopted 53 ft

19 Years Later

- Walmart realised that
 $1.55 + 12.5 + 4.37 > 16.2$
- Walmart approached MTO and asked to run 18.4 m semitrailers
- Analysis showed what was known in 1987, that an 18.4 m semitrailer met the performance standards, and otherwise performed no differently than a 16.2 m semitrailer

18.4 m Extended Semitrailer

- 14-28% increase in cube
- MTO developed a permit program along the lines of the LCV program for these semitrailers
- Operations began in 2014

18.4 m Extended Semitrailer



Another



Front Outswing

- Front outswing is the limiting performance measure for an extended semitrailer
- MTO chose to control it by restricting tractor wheelbase between 5.0 and 5.50 m (197 to 216 in)
- Other performance measures are not worse than for a correspondingly loaded 16.20 m (53 ft) semitrailer

Front and Rear Outswing

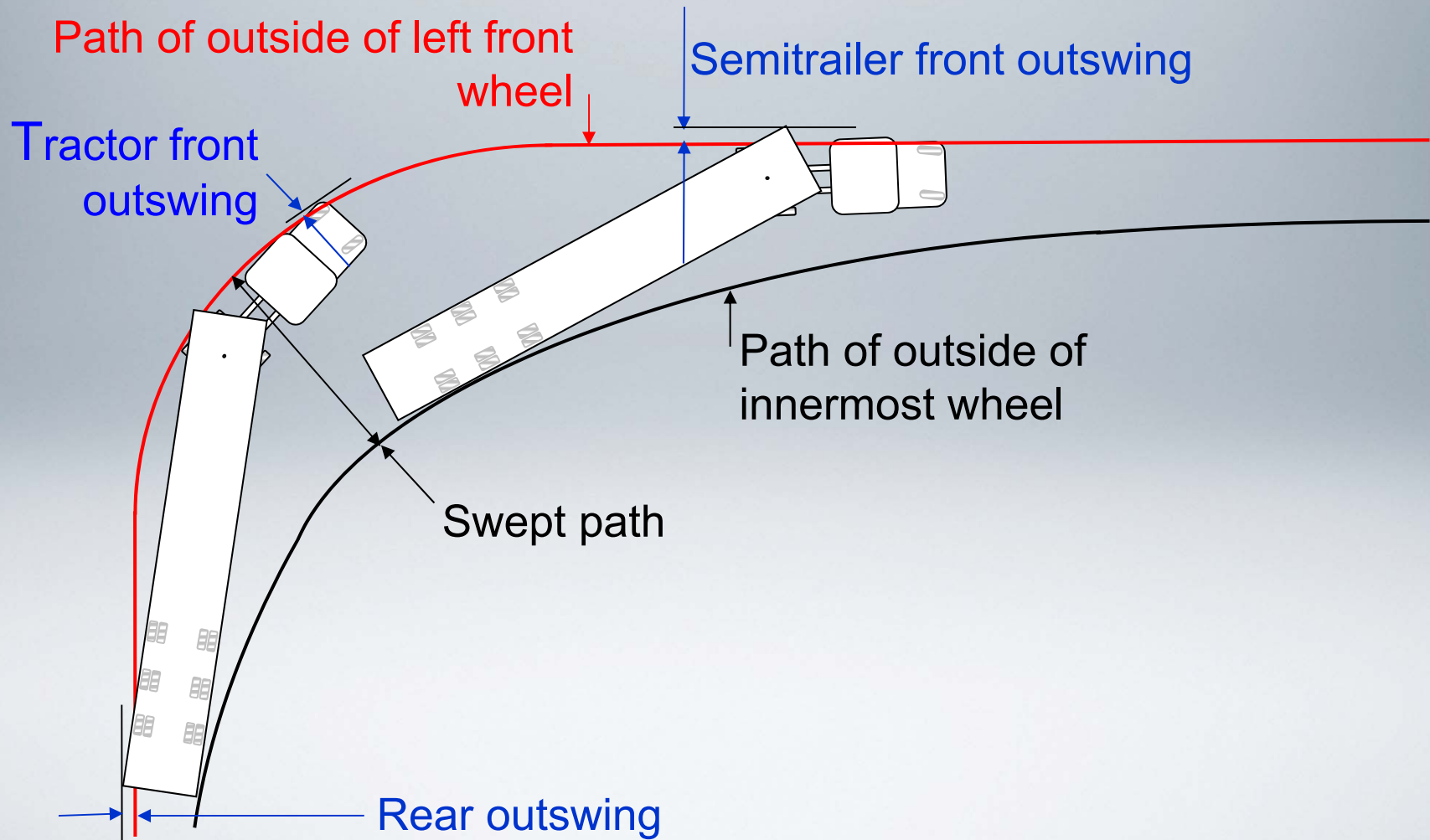

Rear Outswing



Rear Outswing

- The truck driver may not be able to see the left rear corner of the semitrailer, or a vehicle approaching from behind
- Drivers in an adjacent lane may not realise the left rear corner of the semitrailer may swing suddenly into their path, particularly if moving fast
- Rear outswing is critically related to safety
- Performance standard is 0.20 m (8 in)

Front Outswing



Front Outswing

- The truck driver can see the front corner of the semitrailer, and approaching vehicles
- Approaching drivers can see the truck turning
- Either or both drivers can give way if they sense a close encounter
- Front outswing is less critical
- Performance standard for front outswing is 0.46 m (18 in)

Kingpin Setback

- “The horizontal distance from the vertical axis through the center of the kingpin to any point on the semitrailer ahead of the kingpin including load but exclusive of any extension to the length caused by auxiliary equipment or machinery that is not designed for the transportation of goods”

Swing Radius

- For here, swing radius is the greatest distance from the centre of the kingpin to any part of the semitrailer or exclusions or load
- Swing radius depends on
 - Kingpin setback
 - Semitrailer front corner profile
 - Attachments at the front excluded from the semitrailer length measurement and
 - Any front overhang of payload

Dimensions

Dimension	M.o.u. Maximum	Typical 16.20 m	Extended
Swing radius	2.00 m	1.55 m	2.00 m
Wheelbase	12.50 m	11.29- 12.50 m	12.50 m
Effective RO	35% WB	35 - 22% WB	35% WB
KP Setback		0.91 m	1.4-1.52 m

Swing Radius of Typical 16.20 m Semitrailer

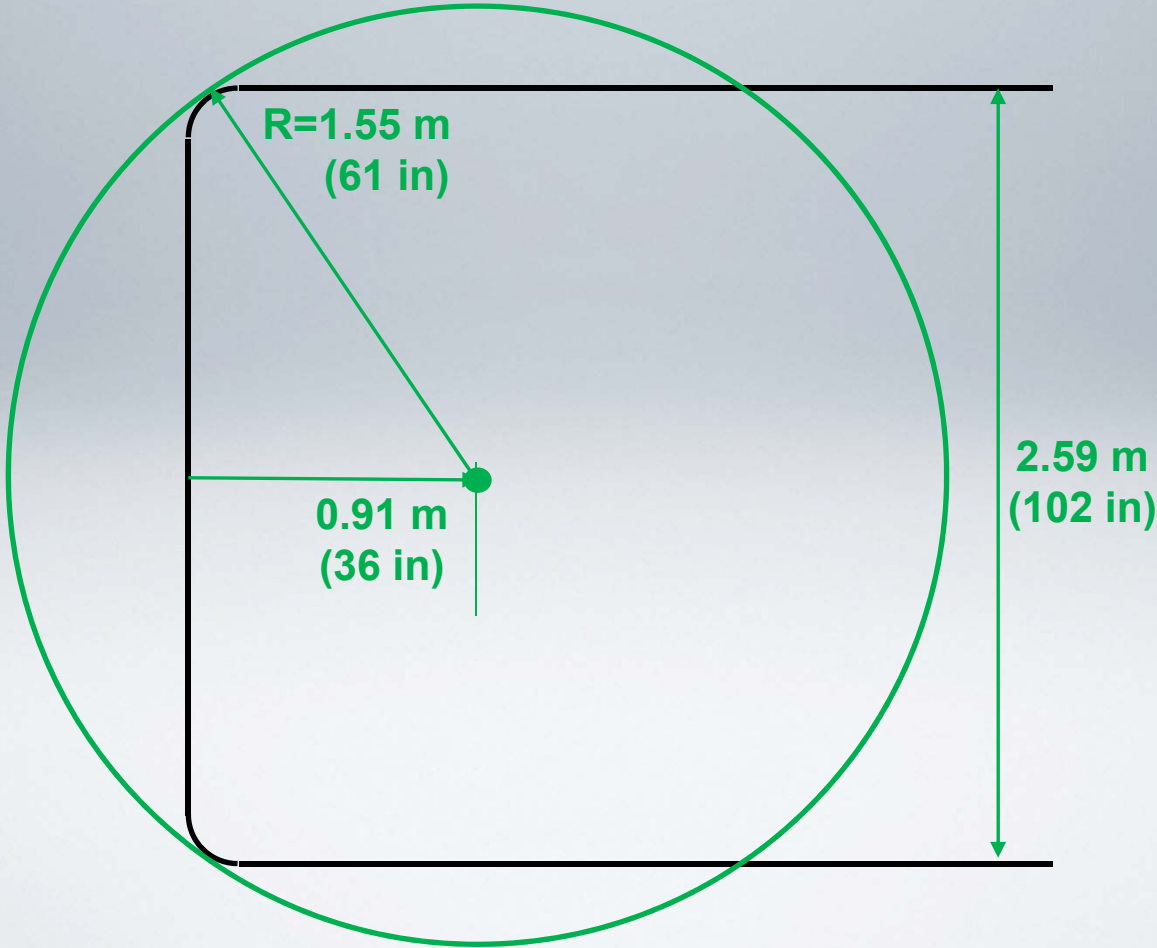

Swing Radius of 16.20 m Semitrailer with Reefer

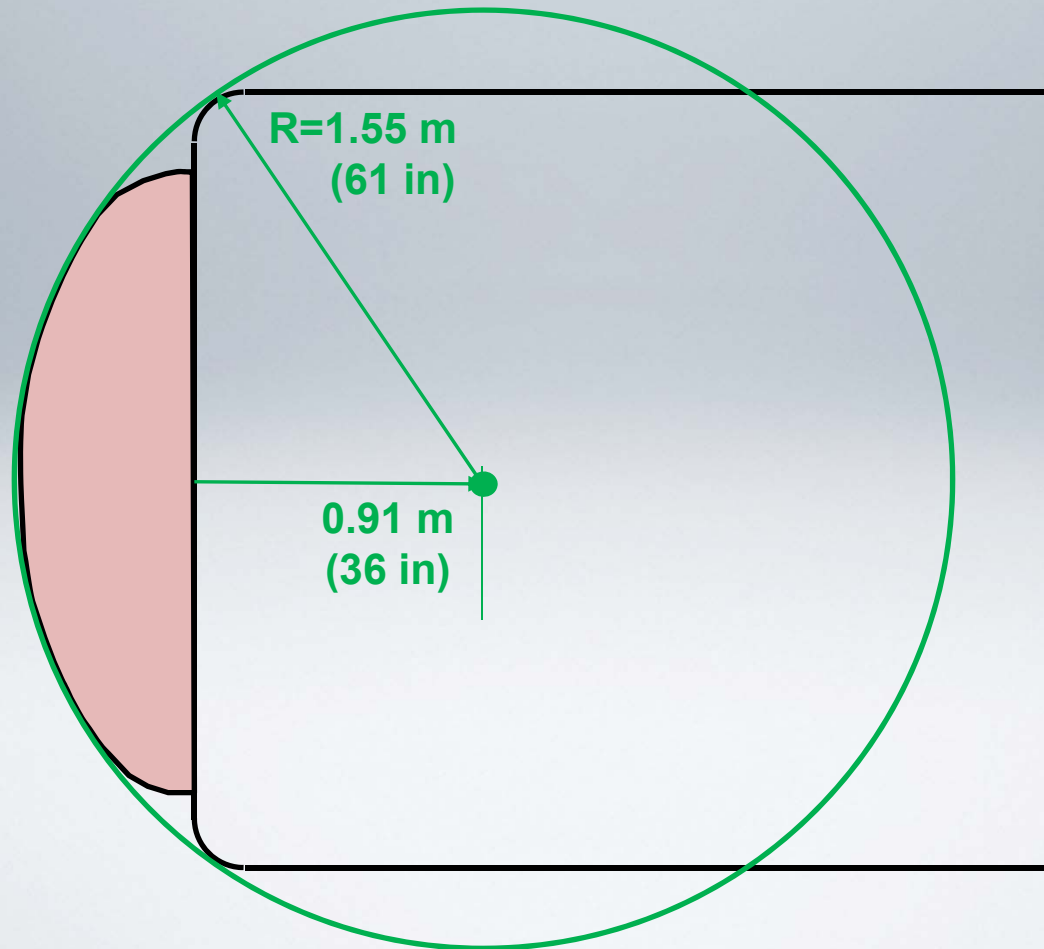

Swing Radius of Extended Semitrailer

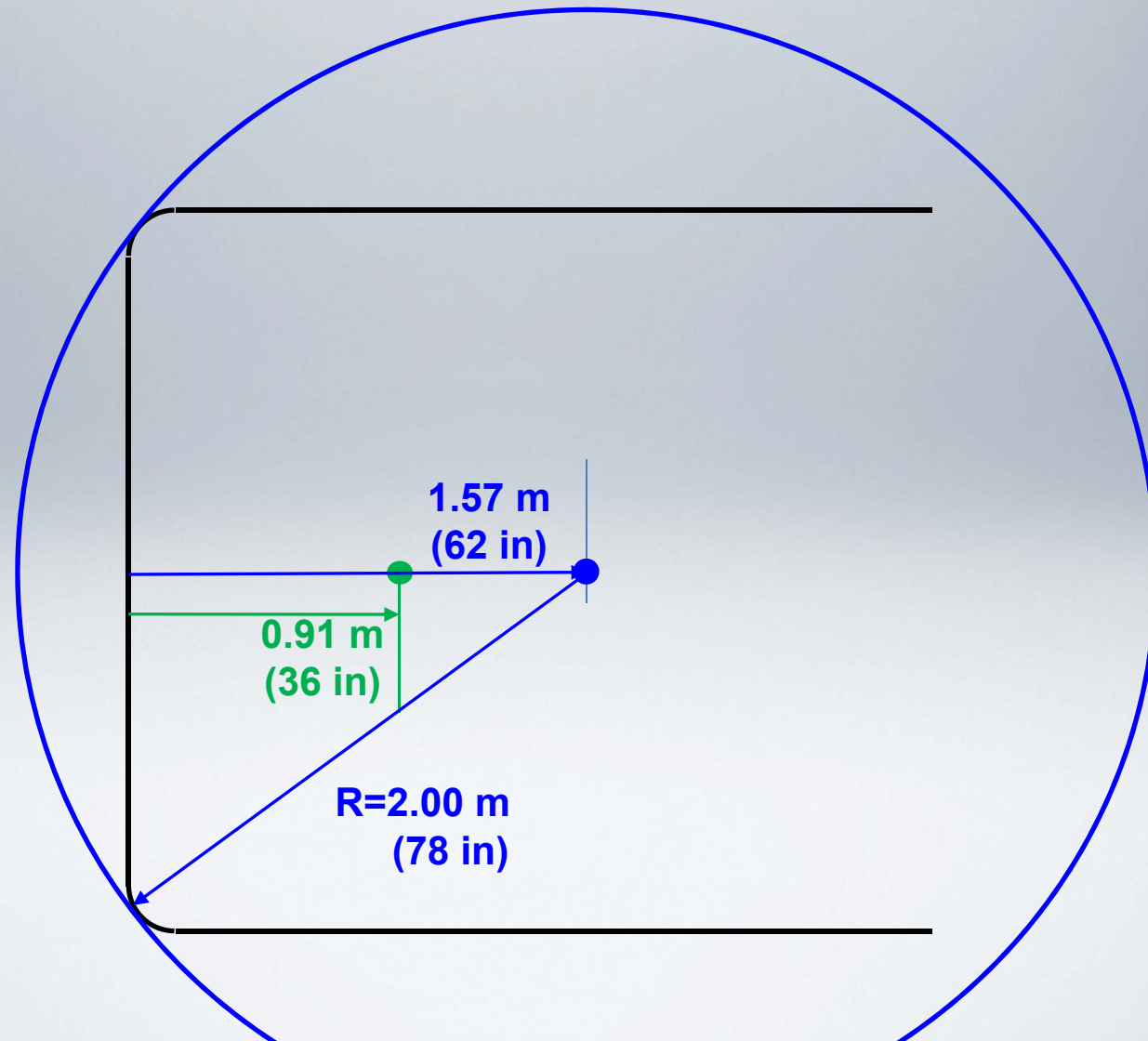

Swing Radius of Extended Semitrailer with Reefer

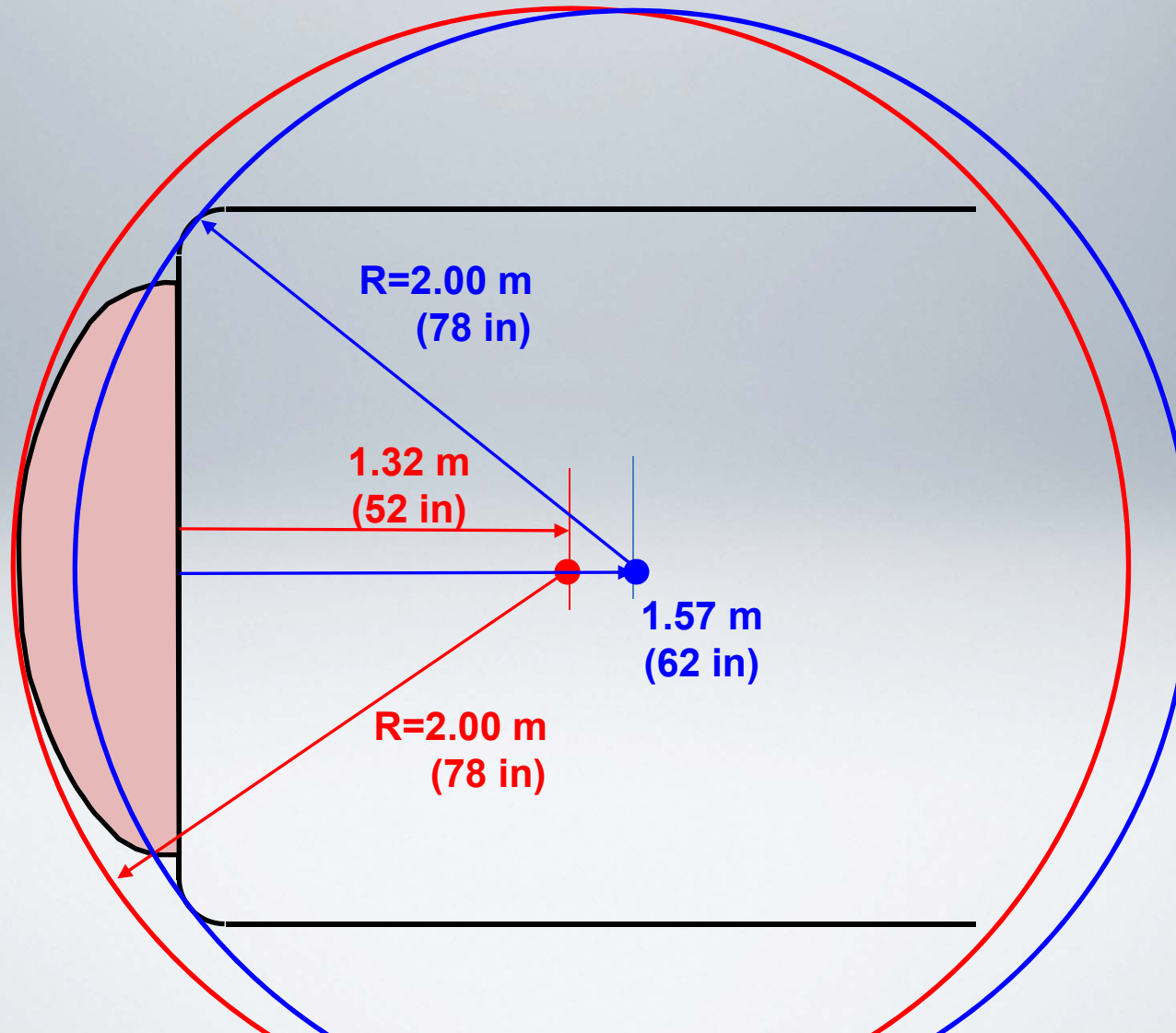

Swing Radius of Extended Container Chassis

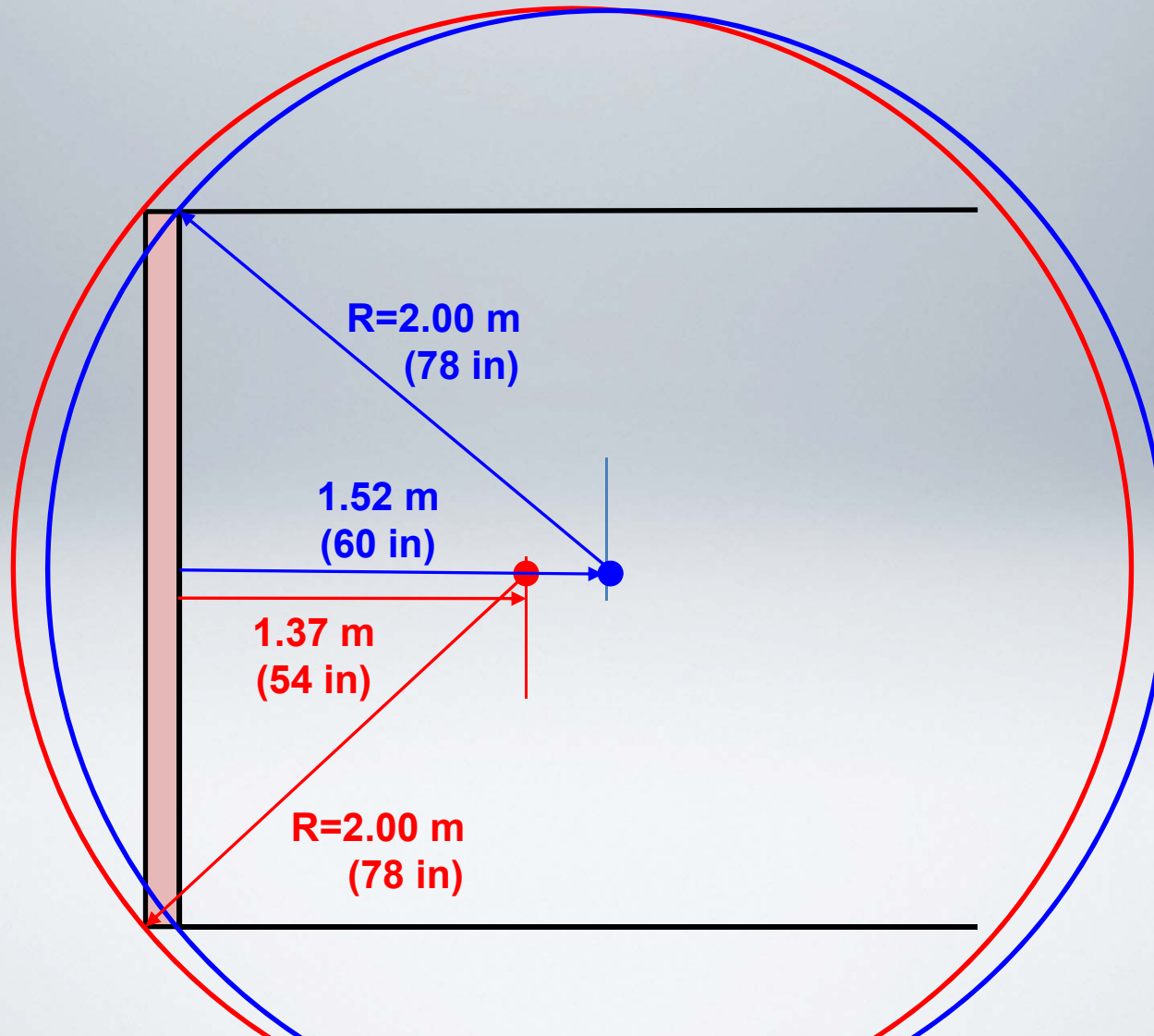

Options for Maximum Kingpin Setback

- Large radius or chamfer on front corners of semitrailer
- Inset reefer
- Chamfer container chassis bolster
- Options may be limited by cargo or equipment considerations

Front Outswing

- May be significant for:
 - A power unit with a large front axle setback, or
 - A semitrailer with a large kingpin setback, eg some B-train lead semitrailers, or an extended semitrailer
- Not significant for a full trailer, pony trailer, or other trailers in doubles
- Max 0.46 m (18 in)

Semitrailer Front Outswing

- Semitrailer front outswing increases as
 - Semitrailer swing radius increases
 - Semitrailer wheelbase increases
 - Tractor wheelbase decreases

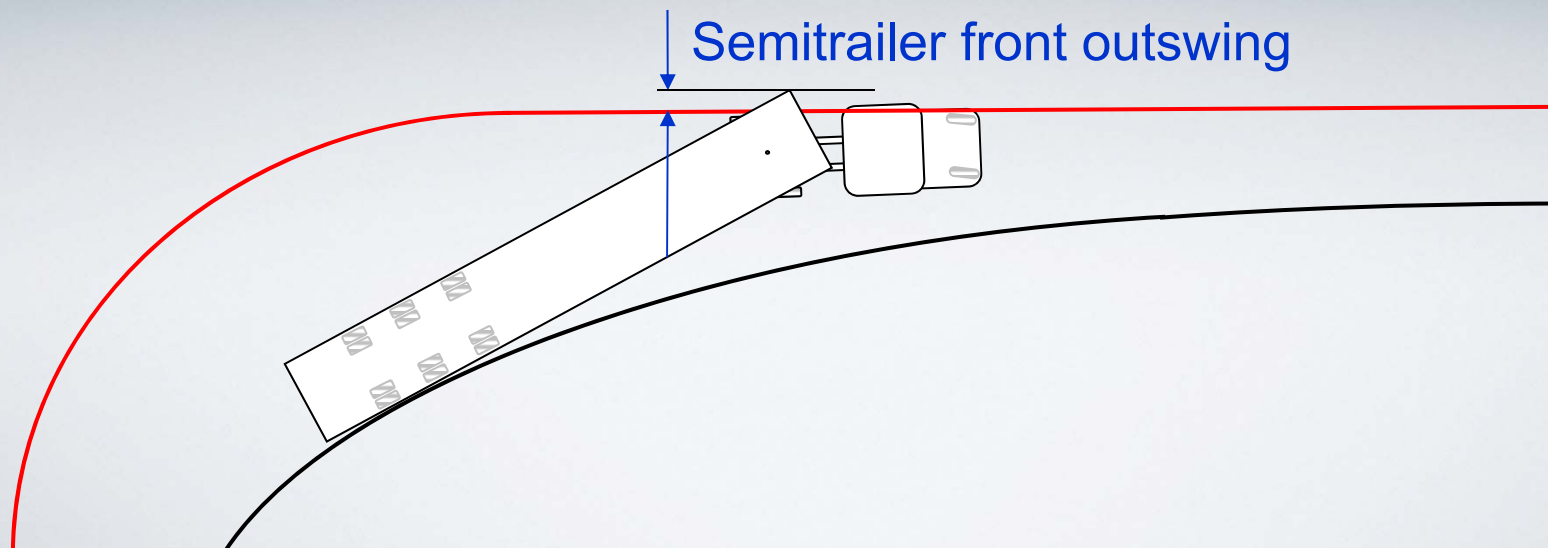

Front Outswing

Tractor Wheelbase	16.20 m Min WB	16.20 m Max WB	Extended
3.81 m (150 in)	0.341	0.353	0.684
4.42 m (174 in)	0.317	0.333	0.637
4.93 m (194 in)	0.296	0.313	0.596
5.49 m (216 in)	0.272	0.291	0.549
6.20 m (244 in)	0.243	0.263	Overlength

MTO Permit

- MTO chose to control front outswing by restricting tractor wheelbase to 5.0 to 5.50 m (197 to 216 in)
- This requires a special tractor where a typical day cab with about 4.42 m (174 in) wheelbase would otherwise work
- It tends to push the vehicle to the outside of a turn, which exacerbates front outswing

Maximum Extended Semitrailer

- Control tractor wheelbase about 4.4 m
- 1.8 m tractor wheelbase reduction allows 0.9 m more semitrailer wheelbase
- 2 m swing radius = 1.55 m kingpin setback
- 13.4 m wheelbase
- 35% rear overhang = 4.7 m
- $1.55 + 13.4 + 4.7 = 19.55$ m (64 ft 3 in)
- 21% increase in cube

19.55 m Maximum Extended Semitrailer

- Shorter wheelbase tractor is more manoeuvrable than 6.20 m wheelbase
- Could chamfer front corners of trailer severely to control front outswing

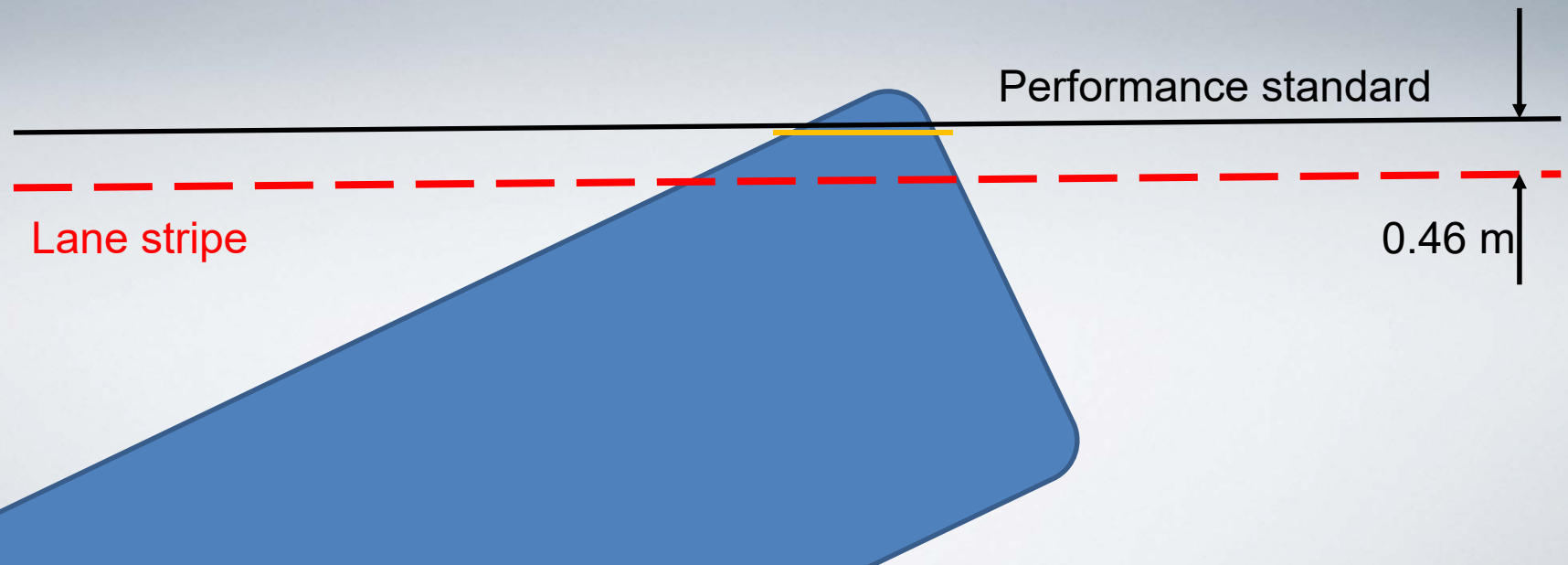

Conclusions

- Front outswing is the limiting performance measure for 18.4 m (60 ft 3 in) extended semitrailers
- MTO chose to control it by restricting tractor wheelbase to 5.0 to 5.50 m (197 to 216 in)
- A shorter tractor wheelbase may allow the semitrailer to about 19.55 m (64 ft 3 in) if the semitrailer front corner is chamfered

Thank you for your attention!