

# 3. b. Québec Update on Issues and Developments

December 7, 2022

Task Force on Vehicle Weights  
and Dimensions Policy

# Achievements 2022

## Departmental Permit Management System (GPM)

### - 2019:

- Special Road Train Operating Permits Regulation (LCV, ≈1,200 permits)
- Regulation respecting special permits (≈44,400 permits)

### - 2022 (October 24):

- Special permits issued under section 633 (≈12,000 permits)  
1986, 1990, 1996, 2018



In the event that a special permit cannot be issued under the *Regulation respecting special permits* or the *Special Road Train Operating Permits Regulation*, the Minister may issue a special permit by virtue of the powers conferred on her under section 633 of the *Highway Safety Code*.

Nom de permis	Coût en 2022
Low combination vehicle - A high - 17.2 m max height (48 K9)	\$0
Truck with a ultra system (196 K9)	\$0
Truck with a high axle ratio in the middle (129 K9)	\$0
Semi-trailer with 40 axles - 40 axles - 40 axles - 40 axles (49 K9)	\$0
Semi-trailer with 30 axles - 30 axles (233 K9)	\$321
Low combination vehicle - car carrier (142 K9)	\$321
22.6 truck driver after car carrier - 22.6 (36 K9)	\$321
Farm vehicle (5.1 m axle dealer or special - other than a trailer) (24 K9)	\$275

# Achievements 2022

## Stinger Steer Car Carrier

September, special permit (section 633 of the HSC) authorizing the operation of a 27.43 m-long stinger steer car carrier, dual highway

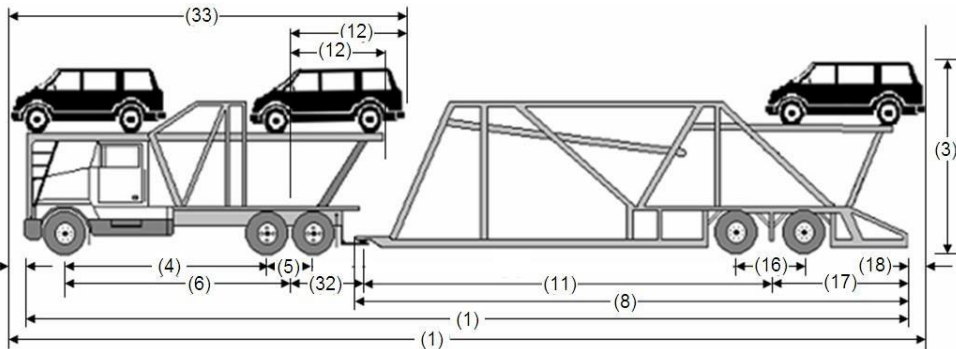

			New special permit Dual highway only	MOU special permit All roads
	Ref	Feature	Dimensional limit	Dimensional limit
Overall	(1)	Overall length	Max. 24.55 m empty, 27.43 m loaded	Max. 23 m empty, 25 m loaded
	(2)	Width	Max. 2.6 m	Max. 2.6 m
	(3)	Height	Max. 4.15 m empty, 4.3 m loaded	Max. 4.15 m empty, 4.3 m loaded
Tractor	(4)	Inter-axle spacing	Min. 3.0 m	Min. 3.0 m
	(5)	Tandem axle spread	1.2 m to 1.85 m	1.2 m to 1.85 m
	(6)	Wheelbase	Not controlled	Not controlled
	(12)	Tractor effective rear overhang	Max. 4.0 m empty, 4.6 m loaded	Max. 4.0 m empty, 4.6 m loaded
	(32)	Hitch offset	Max. 2.5 m	Max. 2.3 m
	(33)	Length	Max. 12.5 m	Max. 12.5 m
	(34)	Front load overhang	Max. 1.22 m	Max. 1 m
	Semitrailer	(8)	Length	Max. 15.24 m
(11)		Wheelbase	6.25 m to 12.5 m	6.25 m to 12.5 m
(16)		Tandem axle spread	1.2 m to 3.10m	1.2 m to 3.10 m
(17)		Effective rear overhang (excluding rear load overhang)	Max. 4.0 m or 42% of wheelbase (whichever is greater)	Max. 4.0 m or 42% of wheelbase (whichever is greater)
(18)		Rear load overhang	Max. 1.83 m	Max. 1.2 m

# Other request: Evaluation after modification of three regulations

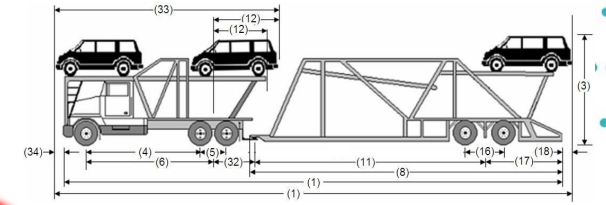

Ref	Feature	New special permit Dual Highway only	Other request All roads	MOU CANADA All roads
		Dimensional Limit	Dimensional Limit	Dimensional Limit
(1)	Overall Length	Max. 24.55m empty, 27.43 m loaded	Max. 24.55m empty, 26.52 m loaded	Max. 23m empty, 25 m loaded
(2)	Width	Max. 2.6m	Max. 2.6m	Max. 2.6m
(3)	Height	Max. 4.15m empty, 4,3 m loaded	Max. 4.15m empty, 4.3 m loaded	Max. 4.15m empty, 4.3 m loaded
(4)	Inter-axle Spacing	Min. 3.0m	Min. 3.0m	Min. 3.0m
(5)	Tandem Axle Spread	1.2 to 1.85m	1.2 to 1.85m	1.2 to 1.85m
(6)	Wheelbase	Not controlled	Min 6.05m	Not controlled
(12)	Tractor Effective Rear Overhang	Max. 4.0m empty, 4,6 m loaded	Max. 4.0m empty, 4,6 m loaded	Max. 4.0m empty, 4,6 m loaded
(32)	Hitch Offset	Max. 2.5m	Max. 2.3m	Max. 2.3m
(33)	Length	Max. 12.5m	Max. 12.5m	Max. 12.5m
(34)	Front Load Overhang	Max. 1.22 m	Max. 1.0 m	Max. 1 m
(8)	Length	Max. 15.24 m	Not controlled	Max. 14.65m
(11)	Wheelbase:	6.25 to 12.5m	10.75 to 12.5m	6.25 to 12.5m
(16)	Tandem Axle Spread	1.2 to 3.10m	1.2 to 3.10m	1.2 to 3.10m
(17)	Effective Rear Overhang (excluding rear load	Max. 4.0m or 42% of wheelbase (whichever is greater)	Max. 4.0m or 42% of wheelbase (whichever is greater)	Max. 4.0m or 42% of wheelbase (whichever is
(18)	Rear Load Overhang	Max. 1.83m	Max. 1.2m	Max. 1.2m
(19)	Track Width			
	Trailer with single tires built before 2010	2.3 to 2.6m	2.3 to 2.6m	2.3 to 2.6m
	Trailer with single tires built after 2009	2.45 to 2.6m	2.45 to 2.6m	2.45 to 2.6m
	All other trailers	2.5 to 2.6m	2.5 to 2.6m	2.5 to 2.6m

# Facing a growing challenge with normative consistency, fairness and simplicity

- change requests
- complexity of the regulations
- dynamic performance
- road design standards
- safety, economy, environment, etc.



27.5 m indivisible load

30 m indivisible load

23 m

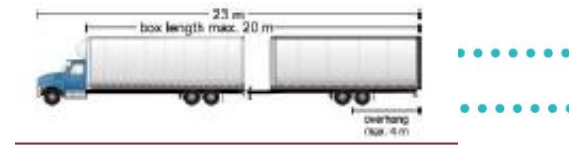

23 m

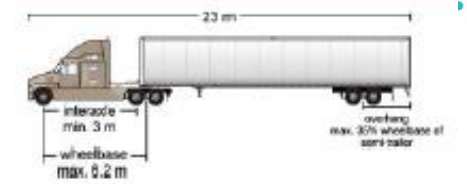

25 m

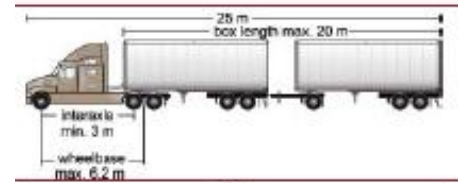

27.5 m

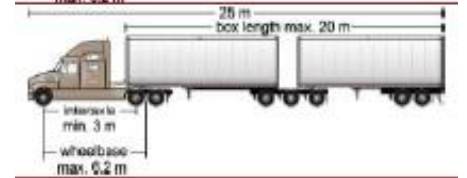

27.5 m dual highway

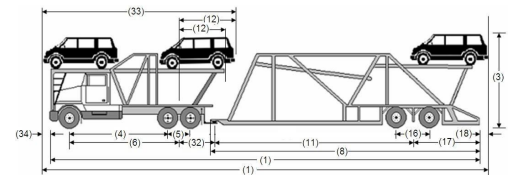

27.5 m indivisible load

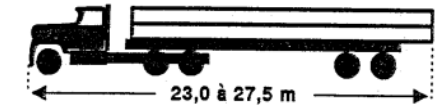

30 m indivisible load

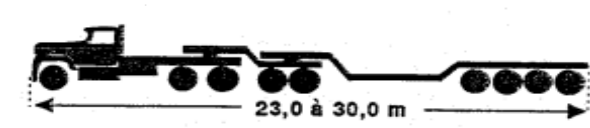

40 m dual highway

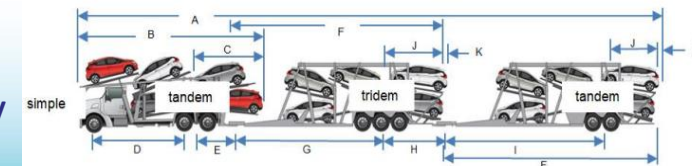



# Planning

## 2023 reform:

- Vehicle Load and Size Limits Regulation 1991, 1998, 1999, 2010, **2013**  
90% of modifications were authorized by permits 633.
- Special Road Train Operating Permits Regulation 1987, 1999, **2005**, 2014, 2019  
Lift axles are still not allowed.

## 2024 reform:

- Regulation respecting special permits 1990, **1993**, 1999, 2010, 2019

# Government and Industry Consultation Table on Load and Dimension Standards

October 10, 2012

7

The Table is still the best way to make a normative change request and make its processing efficient.

## Requests to process

- Tow truck
- Loader with snow blower
- LNG, overload 1,500 kg + 30 cm on the length
- Three drive truck
- Set of three recreational vehicles
- 60'6" semi-trailer
- Truck with two front axles and three rear axles



Search

Québec 511 > Rest Areas

## Rest Areas

- Traffic Cameras
- Interactive Map
- Road Conditions
- Trucking 
  - Hindrances Related to Load and Size
  - Vertical Bridge Clearances
  - Load Limits on Bridges
  - Trucking Network
- Rest Areas**
- Villages-relais
- Useful Links

### By Tourism Region

- ▮ Abitibi-Témiscamingue
- ▮ Baie-James et Eeyou Istchee
- ▮ Bas-Saint-Laurent
- ▮ Cantons-de-l'Est
- ▮ Centre-du-Québec
- ▮ Charlevoix
- ▮ Chaudière-Appalaches
- ▮ Duplessis
- ▮ Gaspésie
- ▮ Îles-de-la-Madeleine
- ▮ Lanaudière
- ▮ Laurentides
- ▮ Manicouagan
- ▮ Mauricie
- ▮ Montérégie
- ▮ Outaouais
- ▮ Québec
- ▮ Saguenay-Lac-Saint-Jean

### By Road



1<sup>er</sup> DÉCEMBRE  
Pneus d'hiver obligatoires

### Services Available

Picnic table	Washroom facilities
Drinking water	Telephone
Non-potable water	Electric vehicle charging station



# Rest areas (nearly 142 safe stopping places)

- 8 service areas
- 16 permanent
- 27 seasonal
- 37 lookouts
- 10 trucker;**
- 44 villages-relais

**Québec Rest Area Network**

<p>Logo CARBURANT RESTAURANT RESTAURANT</p>	<p><b>Service Areas</b> Rest Areas with food and gas services in addition to services typically provided at rest areas.</p>		<p><b>Lookouts</b> Rest Areas with or without services. They include a parking area and typically offer an exceptional view of the surrounding landscape.</p>
	<p><b>Rest Areas</b> These areas provide services including washrooms and a picnic area, and are either permanent or seasonal (open from mid-May to mid-October).</p>		<p><b>Truckers' Rest Areas</b> Rest Areas for truck drivers to rest or check their vehicle and cargo.</p>

## Modernization plan 2022-2027

